

SWISS POWER

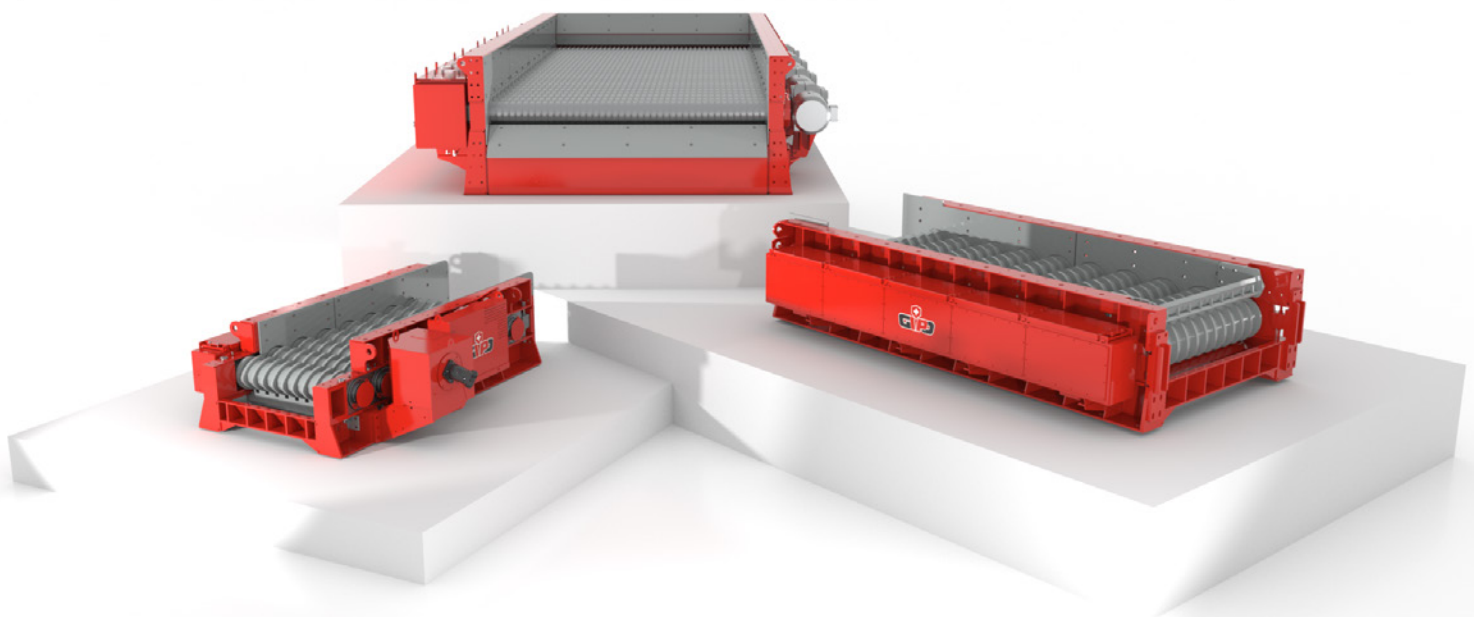

ROLLER GRIZZLY



ROLLER GRIZZLY – THE ROBUST CLASSIFYING DEVICE



The GIPO roller grizzly is the ideal pre-classifying device for feed material containing clay and for heavy feed material. Where conventional pre-screening machines clog and accumulate material, the GIPO roller grizzly impresses with its horizontally rotating rollers and the resulting cleaning function. Downstream plant in the material flow, such as a crusher, profit to a high degree from the preparatory work, which has a noticeable effect on their service life and servicing. The crusher is fed evenly and constantly by the horizontal movement of the rollers.

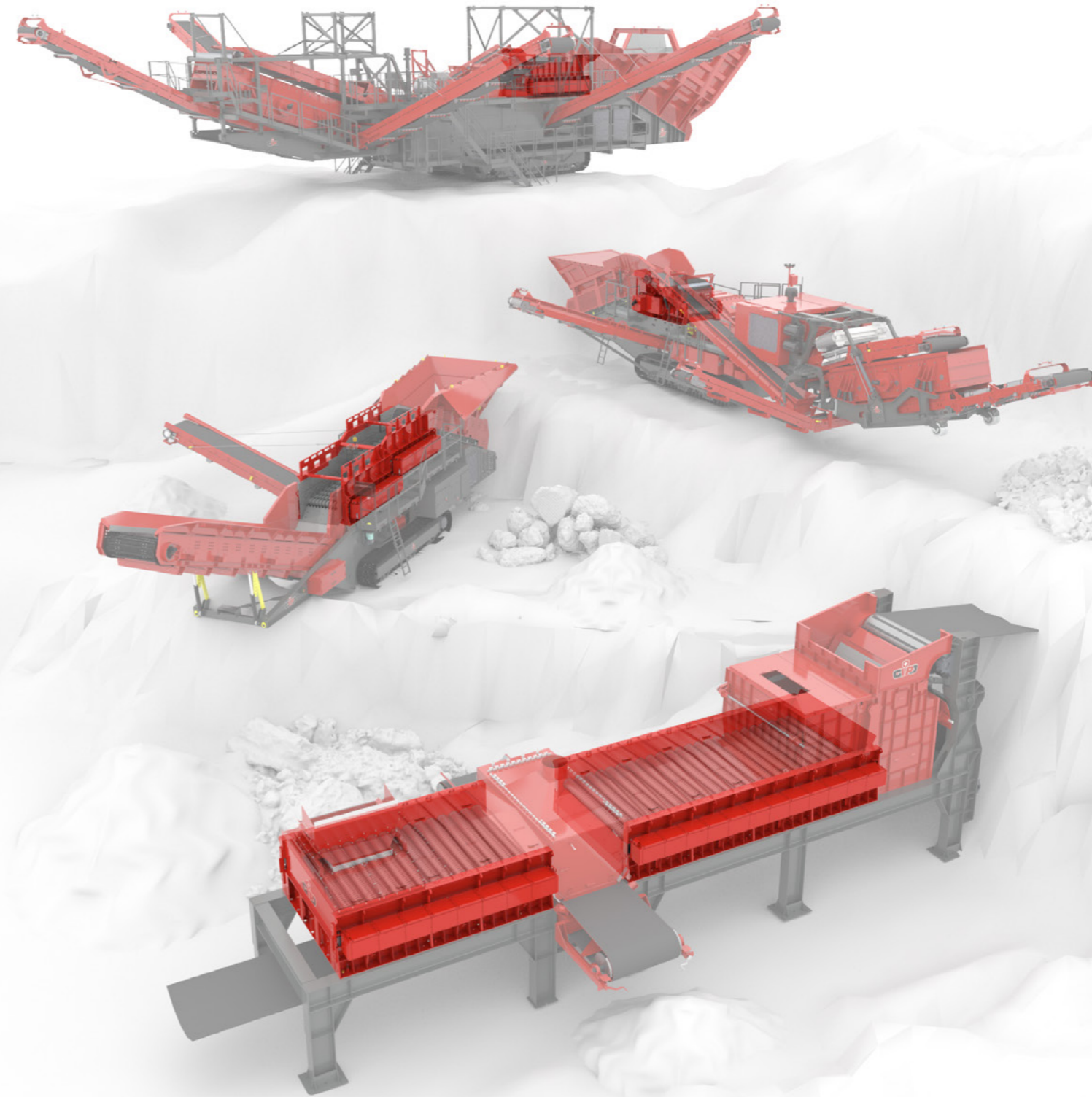
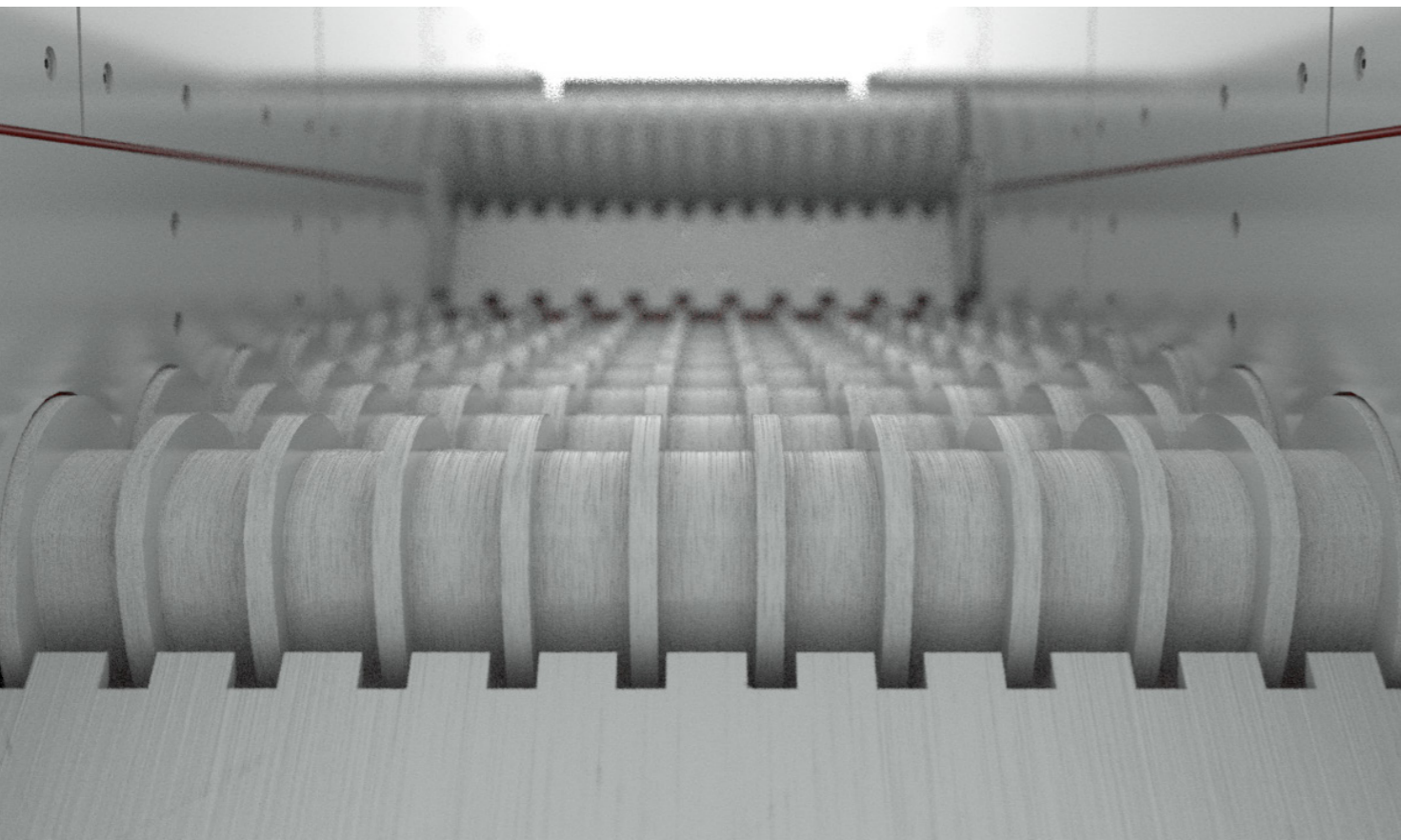

“ **CLEANING DURING EVERY USE** ”

EFFICIENT – MINIMUM VIBRATION – CLEAN

Thanks to the robust construction of the GIPO roller grizzly, vibration in the substructure and undesirable noise can be precluded. The mechanical connection of the shafts always ensures an even material flow. The gap widths can be selected individually for optimal screening with a wide range of materials.

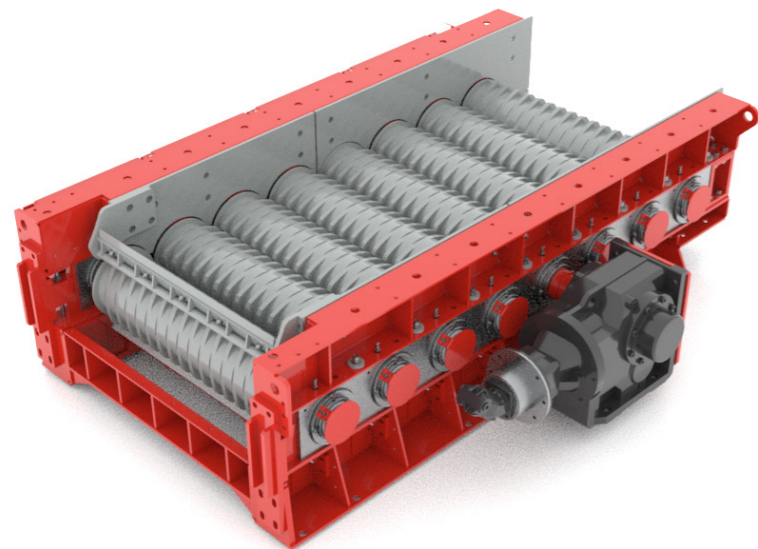
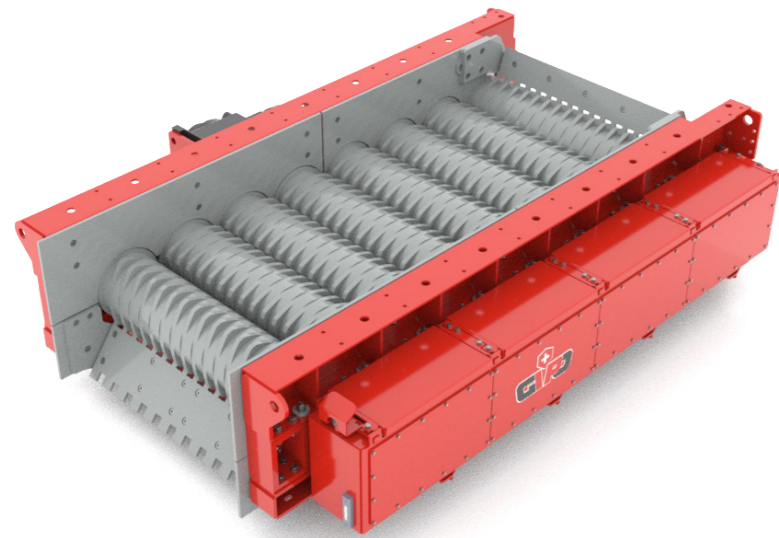

“RELIABILITY ON ROLLERS”

Since 2014 we have been the proud owner of the first roller grizzly GIPOSCREEN RR130-10-10 in France and are still very satisfied with it after more than 5,000 operating hours.



SÉBASTIAN ROCHE
ROCHE GRANULATS

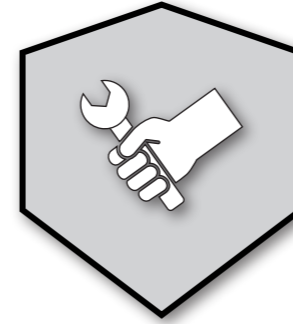

LOW-MAINTENANCE

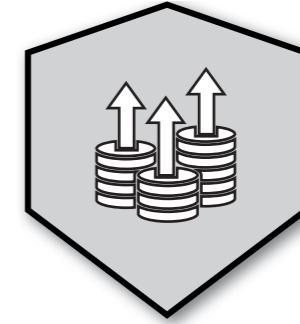

COST-EFFECTIVE

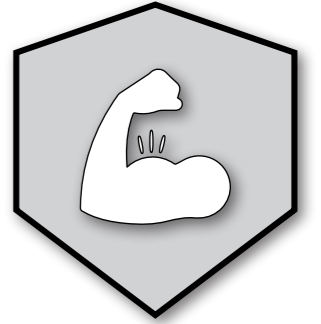

ROBUST

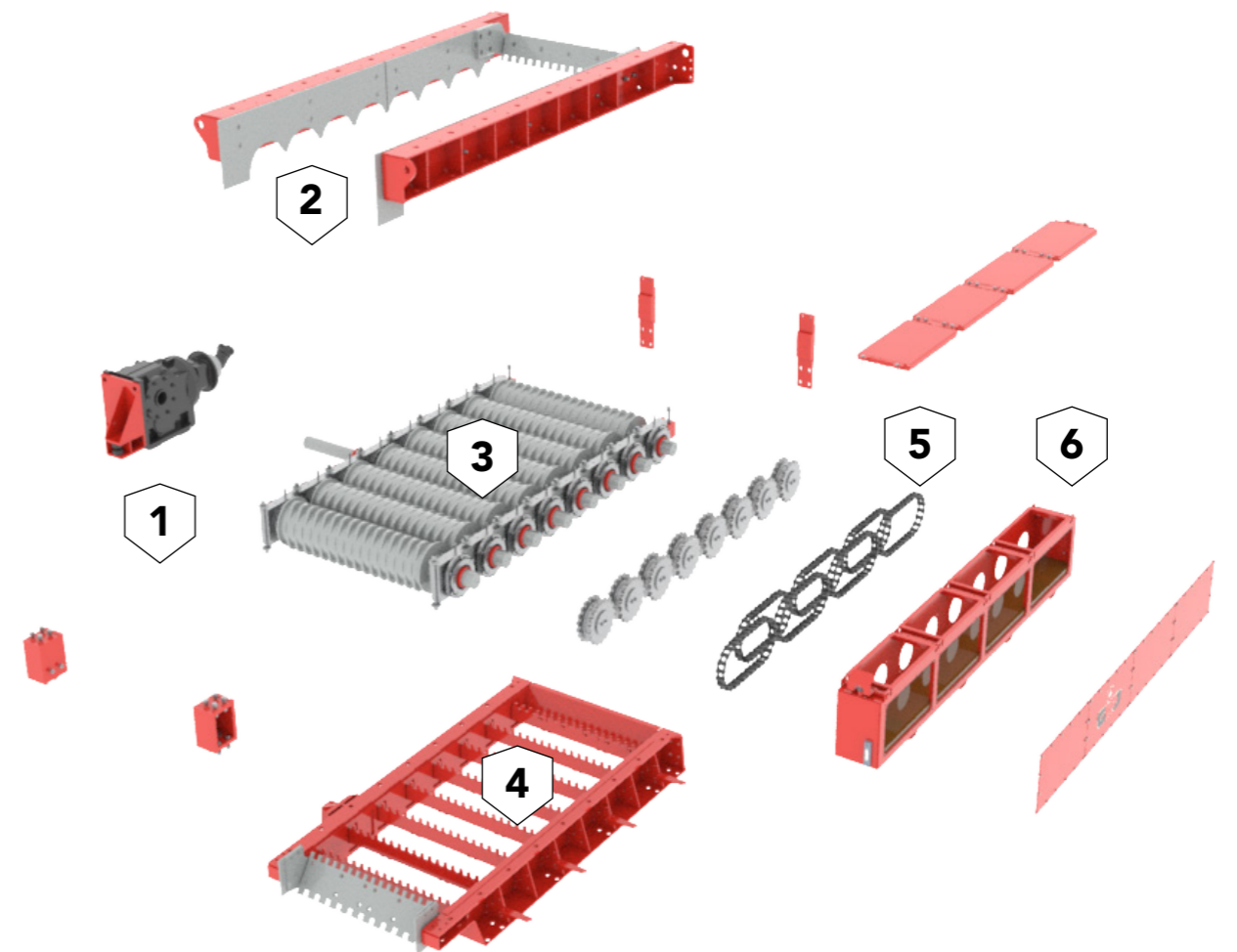

1 Drive

2 Walls

3 Shaft package

4 Base frame

5 Chains

6 Chain box



MAIN FEATURES

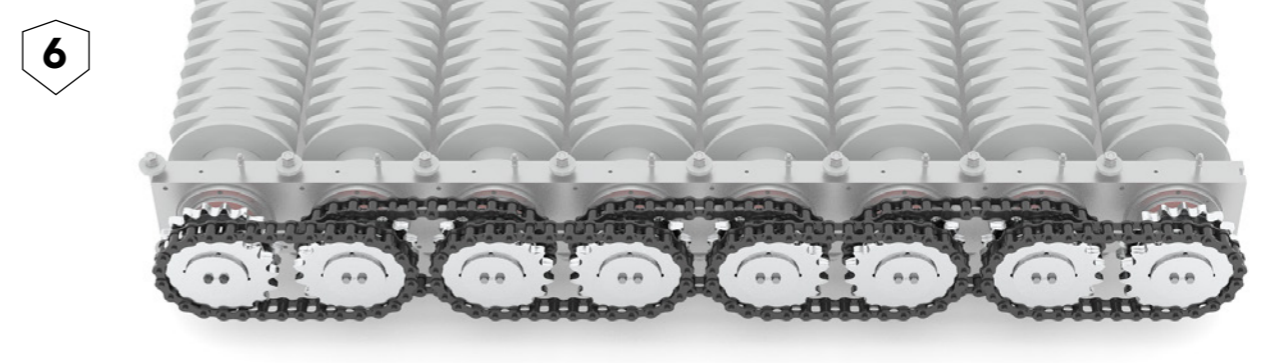
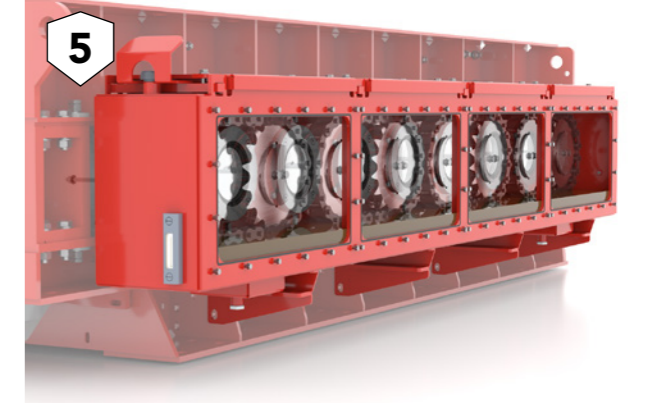
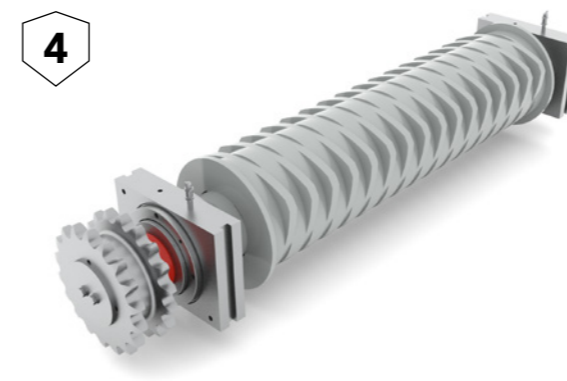
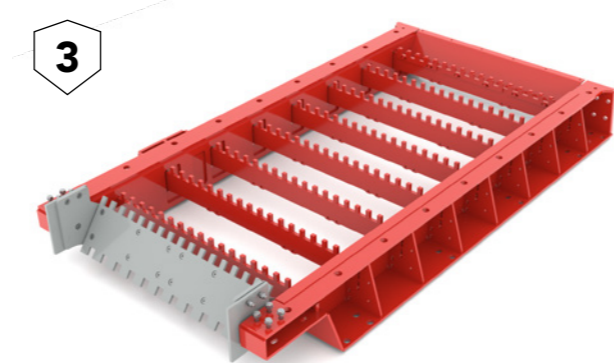
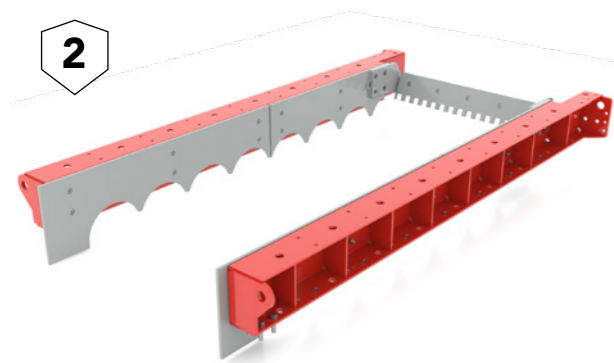
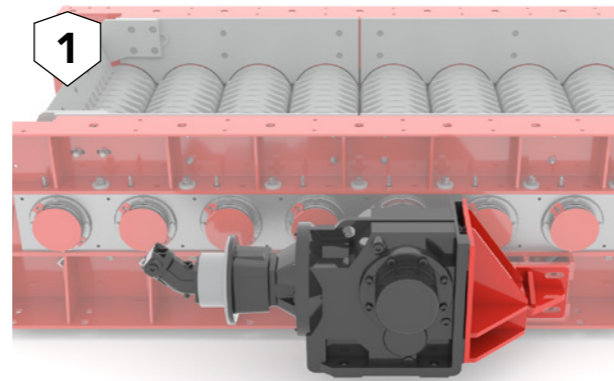
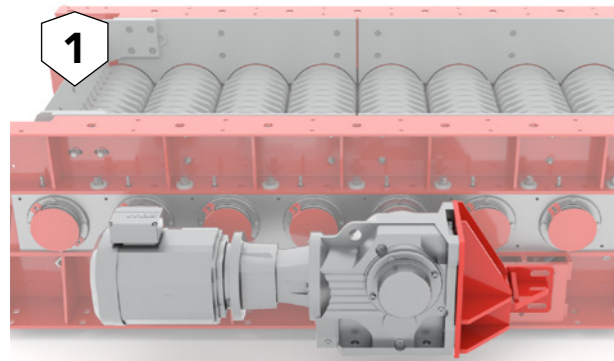

1 DRIVE

Best power transmission due to the planetary shaft-mounted gearbox, with either hydraulic or electric drive motor.

2 WALLS

The transition and the side walls are lined with replaceable wearing plates. An additional height increase can be fitted if required.

3 BASE FRAME

The lower supporting frame is used to support the heavy components. In addition, the roller scrapers are also integrated into the frame; these scrapers ensure optimal cleaning of the rollers.

4 SHAFT PACKAGE

The roller grizzly shafts are designed as square section steel shafts fitted with drive cams and spacers. The drive cams and spacers are made of high-quality wear-resistant steel.

5 CHAIN BOX

The chains and sprockets run in an oil bath that ensures continuous lubrication.

6 CHAINS

Specially designed chains engage with the sprockets to ensure invariably even movement of the shaft packages. Operation in reverse is therefore also possible.



STAGE ARRANGEMENT



1 STAGE

- Primary cleaning
- The moist material and material containing clay are separated
- Gap width can be selected as required
- Primarily used as pre-classification for crushers

2 STAGES

- Primary and secondary cleaning
- The moist material and material containing clay are separated
- The material rolls through the stage – even better cleaning
- Gap width can be selected as required for two different particle sizes
- Can be used as pre-classification and coarse-lump pre-classification

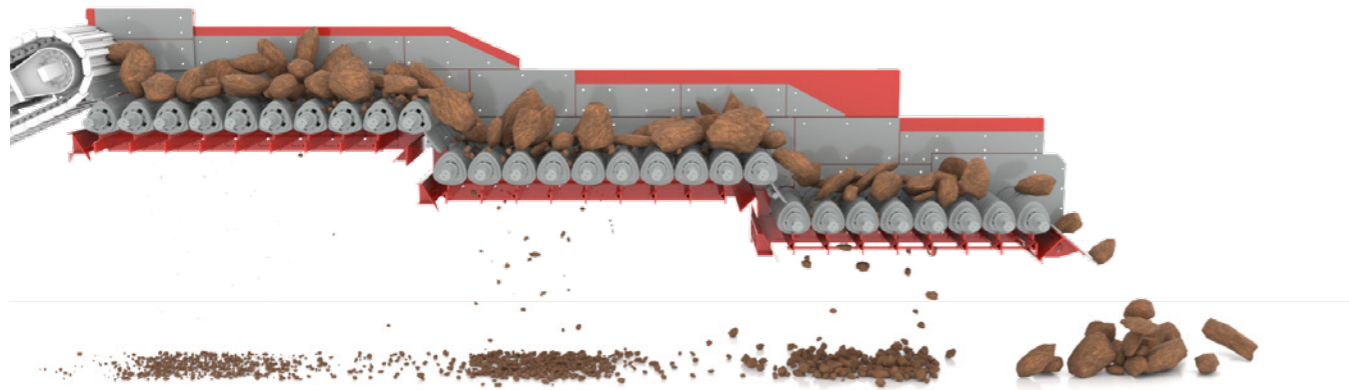

3 STAGES

- Primary, secondary and tertiary cleaning
- The moist material and material containing clay are separated
- The material rolls through the stages – even better cleaning
- Gap width can be selected as required for three different particle sizes
- Primarily used as coarse-lump pre-classification

"EFFICIENCY IN A LARGE FORMAT"

During coal processing, the GIPO roller grizzly is the ideal tool for low-maintenance, reliable usage. Highest throughput due to generous dimensions.



IOURI METELKINE
M.B.N. INTERNATIONAL CORP.

“**HIGH THROUGHPUT PERFORMANCE DURING THE PRE-CLEANING ALSO OF LIGHTER MATERIAL**”



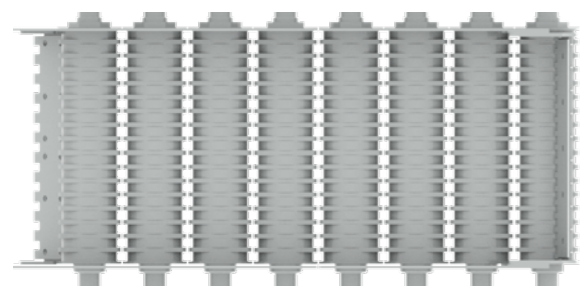

- Small bearing – gap from 40 mm to 80 mm
- Circular spacers
- Usually 8 rollers
- Useful width from 800 mm to 1,100 mm

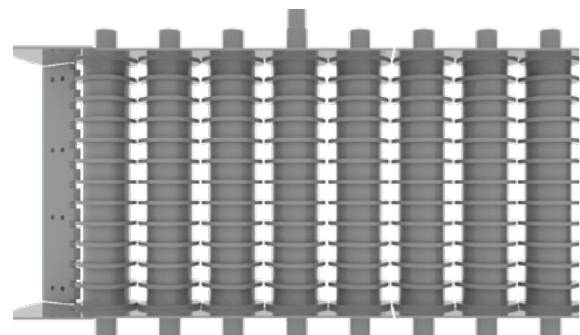

- Large bearing – gap from 80 mm to 120 mm
- Triangular spacers
- 8 to 10 rollers
- Useful width from 1,100 mm to 1,700 mm

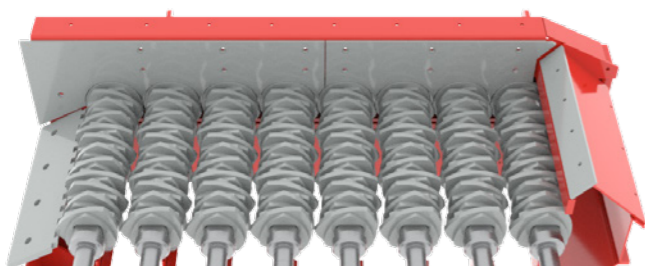

- On request the drive cams and spacers can also be fitted offset in relation to each other
- Better distribution over the entire width of the roller grizzly

ROLLERS AND GAP DIMENSION

The configuration of the roller axles specifies the required particle size. With two different standard bearing sizes, gap widths from 40 mm to 120 mm can be set. The special Reuleaux triangular shape of the drive cams produces a wave motion in the material and in this way ensures constant forward movement. From a specific gap width, these triangular drive cams are also designed as spacers in this shape so that clogging can be prevented. Depending on the degree of contamination of the feed material, the number of rollers is increased to safeguard the cleaning.



TECHNICAL DATA SHEET

Roller grizzly	Useful width NB approx. (mm)	Number of rollers	Gap dimension approx. (mm)	Drive power approx. (k-W)	Total weight approx. (t)	External length A approx. (mm)	External width B approx. (mm)	External height C approx. (mm)
RR 090/8	870	8	40-80	11	6.5	2,800	1,600	900
RR 100/8	970	8	40-80	15	7.0	2,800	1,700	900
RR 110/8	1,070	8	40-80	18.5	8.0	2,800	1,800	900
RR 130/8	1,270	8	40-120	22	10.0	3,300	2,100	900
RR 130/10	1,270	10	50-120	30	12.0	4,000	2,100	900
RR 150/8	1,500	8	50-120	45	11.0	3,300	2,300	900
RR 150/10	1,500	10	50-120	55	13.0	4,000	2,300	900
RR 170/8	1,700	8	50-120	45	12.0	3,300	2,500	1,000
RR 170/10	1,700	10	50-120	55	14.0	4,000	2,500	1,000

Along with our standard sizes, which are matched to downstream plant from GIPO AG in the processing chain, bespoke designs can also be manufactured. The number of rollers and the gap dimension are manufactured to suit customer requirements. Dimension X may vary depending on the design of the drive (hydraulic or electric).

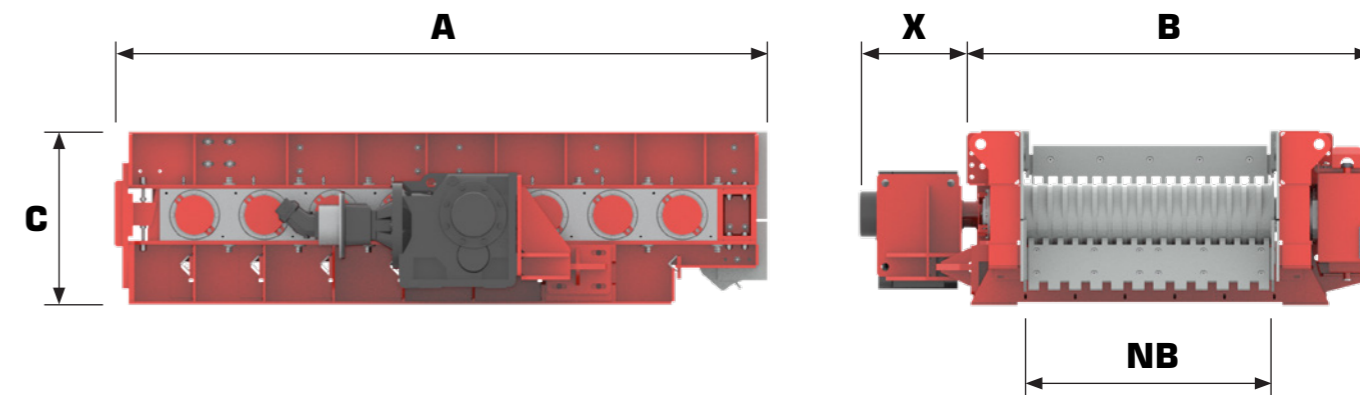

* The values stated in relation to the crushing performance and feed material lump size are heavily dependent on the characteristics of the feed material (condition/abrasiveness, particle size distribution, portion of fine material, etc.), the required final particle size, optimal operation of the plant and feeding, as well as the correct adjustment of the plant.





GIPO AG
Industriegebiet See, Zone C
Kohlplatzstrasse 15
CH-6462 Seedorf

T +41 41 874 81 10
info@gipo.ch
www.gipo.ch
Schweiz / Switzerland / Suisse



Figures and text are for information only and may include options.
Subject to technical change. Performance data are dependent on
the application conditions.